

3V3 SUPPLY

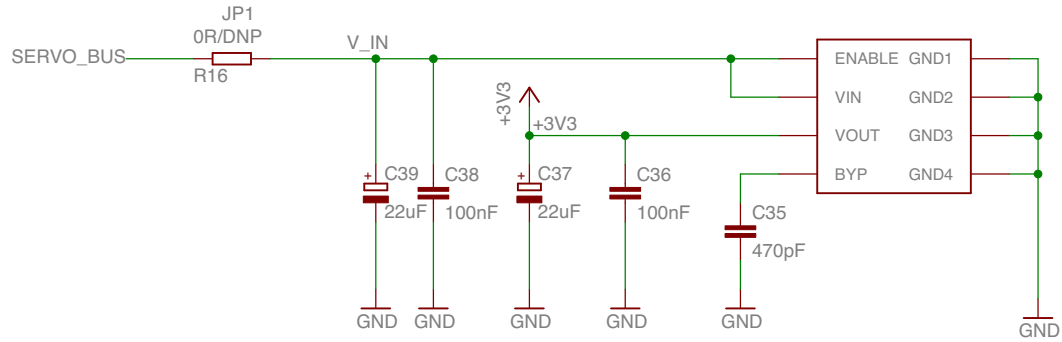

5V SUPPLY

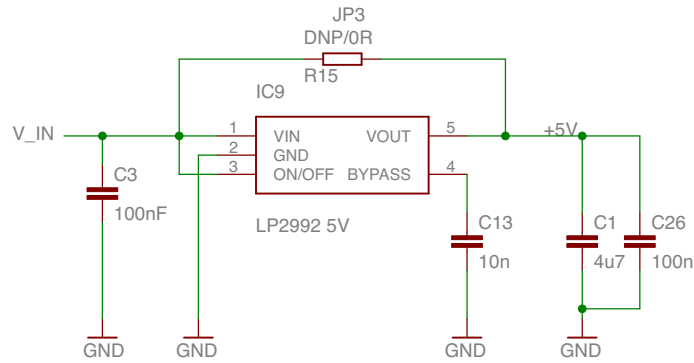

Servos Board

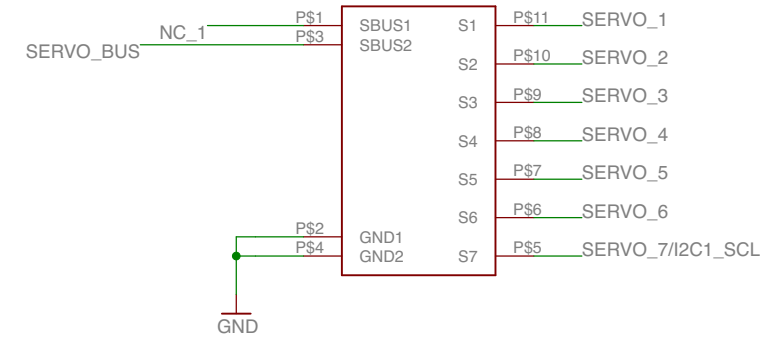

IMU

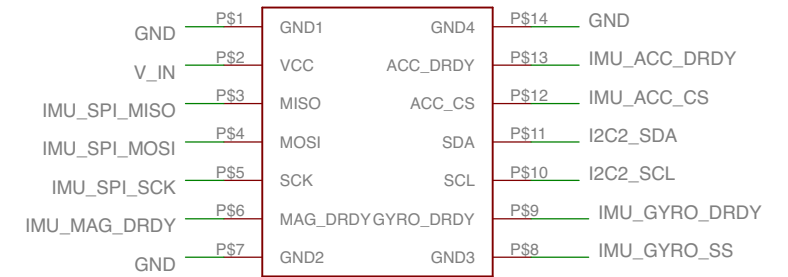

BARO

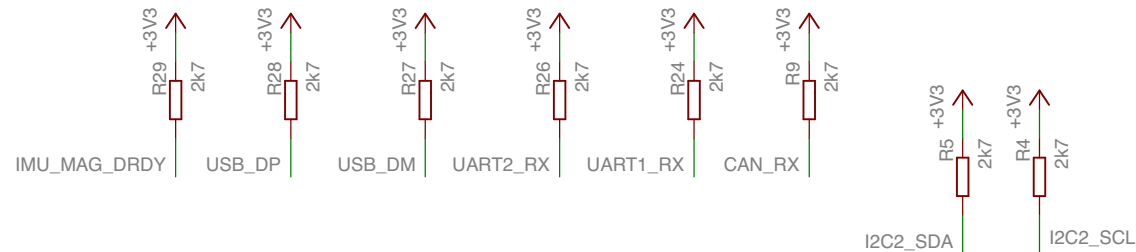
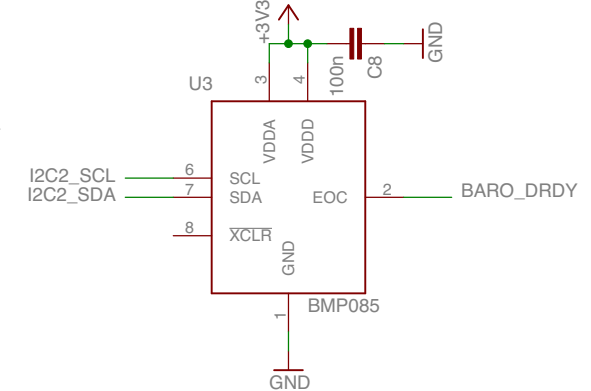

STM32F105RCT6
FLASH = 256KB
RAM = 64KB

STM32-C-64



(C) 2010-2011 Antoine Drouin <poinix@gmail.com> (C) 2011 Richard Hatano <rhatano@jobyenergy.com>
(C) 2010-2011 Piotr Esden-Tempski <piotr@esden.net> (C) 2011 Joby Robotics <info@jobyrobotics.com>
License: CC-BY-SA 3.0
<http://creativecommons.org/licenses/by-sa/3.0>

TITLE: lisa_m	
Document Number:	REV:
Date: 6/8/11 8:30 PM	Sheet: 2/3